



“SINGLE POINT”

CODE COMPLIANT HANDWASHING HEATERS

Instant Comfort...Endless Savings

ELECTRIC TANKLESS WATER HEATERS

9/06

MODELS:

	Volts	kW	Amps
SP2412	120V	2.4kW	20A
SP3012	120V	3.0kW	25A
SP3512	120V	3.5kW	29A
SP3208	208V	3.0kW	14.4A
SP4208	208V	4.1kW	19.7A
SP35	240V	3.5kW	14.6A
SP48	240V	4.8kW	20A
SP55	240V	5.5kW	22.9A
SP3277	277V	3.0kW	10.8A
SP4277	277V	4.1kW	14.8A

SPECIFICATION OPTIONS

- FC = Flex Connector braided-stainless steel water connections available. (EX176, EX177)
Example: SP3512FC

APPLICATIONS:

- Shopping Malls
- Office and Tenant Spaces
- Commercial Buildings (restaurants, etc.)
- Modular Buildings/Modular Offices
- Public Hand Washing
- Service Stations
- Schools
- Concessions Stands, Stadiums

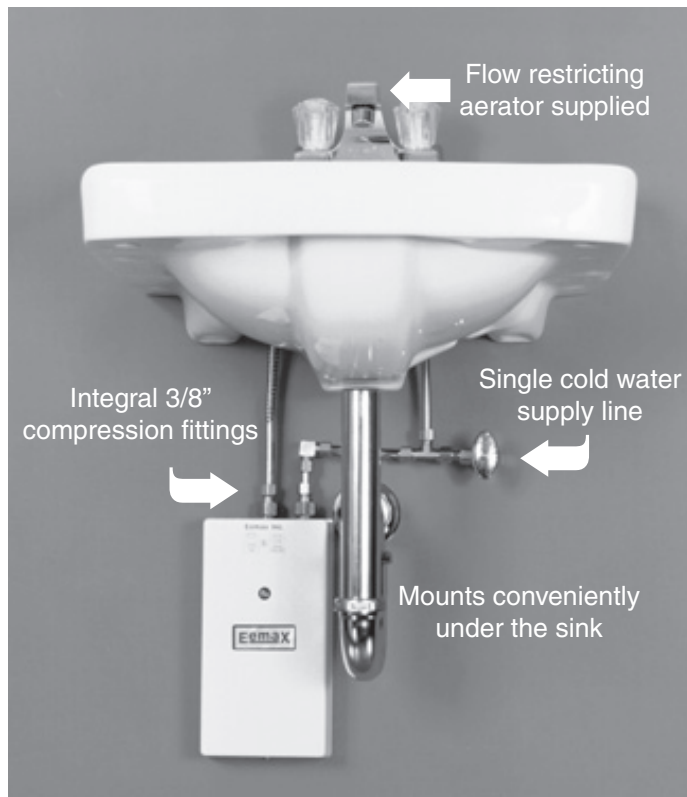

Designed to comply with .5 GPM handwashing code target outlet temperature 105° - 110°.

ADVANCED TECHNOLOGY • HIGHEST EFFICIENCY
DESIGNED FOR DURABILITY

MADE IN USA

QUALITY FEATURES

- **On Demand Hot Water** - no delay.
- **Cut Energy Waste** - flow switch activates heater only on demand (no standby heat loss). **99% efficient**
- **Continuous Hot Water** - no storage capacity to run out.
- **Reduces Installation Cost** - no T & P relief valve needed (check local codes).
- **Easy Installation** - only one cold water line need be brought to lavatory - integral 3/8" compression fittings on top (no sweat connections). Mounts on wall at point-of use.
- **Integral Flow Restrictor** - Built in to ensure proper temperature rise. Complies with U.S. Federal regulations.
- **Faucet Aerator** - with excellent spray pattern supplied with unit.
- **Hands Free**, sensor and metering faucet compatible
- **Prevents Legionella Bacteria Growth**
- **Reduces Liming, Calcification and Sedimentation.**
- **Complies with Handicap Requirements**
- **Ni Chrome Element** - a unique, patented flow path ensures optimum heat transfer and extended element life.
- **Compact Size** - dimensions 10.75" x 5.25" x 2.875"; weight 3 lbs.
- **Field Serviceable Element** - replaceable cartridge element (1 year warranty).
- **Warranty** - Full Factory Warranty - Heaters are guaranteed against failure due to leaks of "Heater Body/Element Assembly" for a period of FIVE YEARS.
- **High Temperature Limit Switch** - protects against element burn out, with reset button.

SUGGESTED SPECIFICATION

Tankless Water Heater shall be an Eemax Model _____ with _____ vac, _____ to heat 0.5 GPM

@ a temperature rise of _____ degrees F. Unit shall have _____ amperage ABS-UL 94Vo rated cover. Element shall be replaceable cartridge insert. Unit shall have a replaceable filter in the inlet connector and a flow regulator in the outlet connector. Element shall be iron free, nickel chrome material. Heater shall be fitted with 3/8" compression nuts and sleeves to eliminate need for soldering. Heater shall be installed upright with water connections on top only. Hot water storage tanks prohibited. Unit shall be Eemax or approved equal.
NOTE: Refer to rating chart for product information.

NOTE: Flow Activated 0.5 GPM

OPERATING PRESSURE	
Min.	Max.
25 PSI	150 PSI

OPTIONAL FLEX CONNECTOR ACCESSORY (FC)

- Stainless steel braid reinforced flexible water connector.
- 3/8" C x 1/2" FIP - 16" faucet supply (EX176)
 - or
 - 3/8" C x 3/8" C - 16" faucet supply (EX177)

RATINGS OF SINGLE POINT UNITS { Cold water feed only }

MODEL	VOLTS	kW	AMPS	RISE AT 0.5 GPM	RECOMMENDED WIRE SIZE
SP2412	120V	2.4kW	20A	33°	10AWG
SP3012	120V	3.0kW	25A	41°	10AWG
SP3512	120V	3.5kW	29A	48°	10AWG
SP3208	208V	3.0kW	14.4A	41°	14AWG
SP4208	208V	4.1kW	19.7A	56°	12AWG
SP35	240V	3.5kW	14.6A	48°	14AWG
SP48	240V	4.8kW	20A	65°	12AWG
SP55	240V	5.5kW	22.9A	75°	10AWG
SP3277	277V	3.0kW	10.8A	40°	14AWG
SP4277	277V	4.1kW	14.8A	56°	14AWG

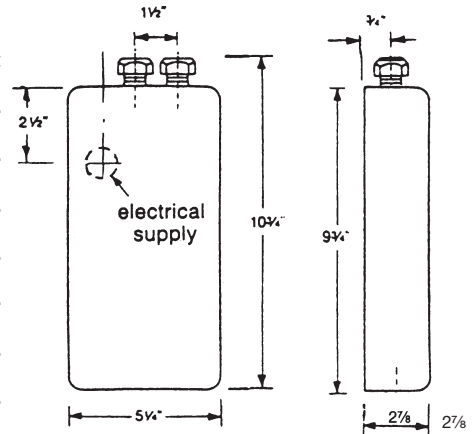

SPECIFICATIONS:

Dimensions: 10.75" x 5.25" x 2.875"

Weight: 3 lbs.

Materials:

Cover: ABS UL rated 94Vo.

Color: White

Element: Replaceable cartridge insert

Pipe-Fittings: 3/8" compression at top of unit

UL Listed: E86887 (M)

U.S. Patent #'s: 4,762,980 and 4,960,976

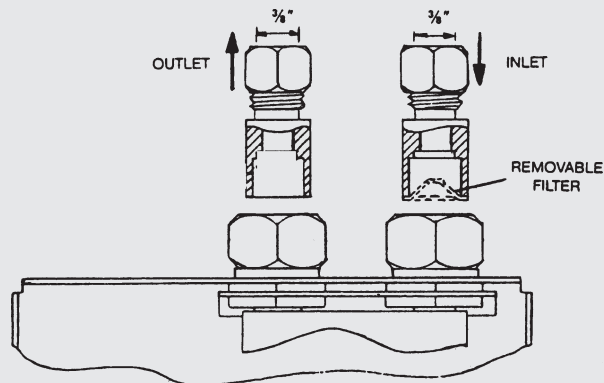

EEMAX SUBMITTAL

Engineer/Architect: _____
 Job Name/Customer: _____
 Location: _____
 Contractor: _____
 Representative: _____
 HEATER SPECIFICATIONS:

Option	Quantity	kW	Voltage	AMPS	GPM
Single Point Model #	SP _____				

SPECIAL DESIGN SERVICE

INQUIRIES FOR UNITS FOR UNIQUE APPLICATIONS ARE WELCOME. CALL OUR TECHNICAL SERVICE DEPT. 1-800-543-6163

Eemax® Inc.

353 Christian Street, Oxford, CT 06478

www.eemax.com

Telephone: (203)267-7890

TOLL FREE: 1-800-543-6163

FAX: (203) 267-7975

EEMAX LIMITED WARRANTY

Subject to the terms and conditions set forth herein, each Eemax Instantaneous Water Heater is warranted against mechanical or electrical failure due to manufacturing defects for a period of one year from the date of manufacture and is warranted against leaks due to manufacturing defects for a period of five years from the date of manufacture.

Subject to the terms and conditions set forth herein, if such heater fails or leaks because of a manufacturing defect during the applicable warranty period set forth above, the Buyer should contact Eemax for a Returned Merchandise Authorization (RMA). No returns will be accepted by Eemax without an RMA number and Eemax assumes no responsibility for product returned without written authorization. Product should be wrapped and packaged securely to avoid shipping damage.

If the product has been thus returned to Eemax within the applicable warranty period and the heater is in fact determined to have failed or leaked because of a manufacturing defect, then Eemax will, at Eemax's election, either repair or replace the defective portion of such product. Eemax shall have no responsibility for any failure or leakage of the product resulting from: (a) the use of the product for other than its intended purpose; or (b) any unauthorized alteration or modification to the product; or (c) improper installation; or (d) any unauthorized repairs or attempted repairs to the product; or (e) any other causes external to the product after delivery.

The Buyer's sole and exclusive remedy on account of any defective product furnished by Eemax shall be to secure the repair or replacement of the defective product from Eemax on the terms and subject to the conditions specified herein. Eemax shall not in any event be liable for any costs incurred by Buyer, including, without limitation, the cost of any labor expended on any product.

EEMAX MAKES NO WARRANTIES OR REPRESENTATIONS, EXPRESS OR IMPLIED, WITH RESPECT TO THE PRODUCT EXCEPT AS SET FORTH ABOVE. EEMAX EXPRESSLY DISCLAIMS THE IMPLIED WARRANTIES OF MERCHANTABILITY AND FITNESS FOR A PARTICULAR PURPOSE. THE REMEDIES SET FORTH ABOVE ARE THE ONLY REMEDIES AVAILABLE TO THE BUYER OR ANY PERSON FOR BREACH OF ANY COVENANT, DUTY OR OBLIGATION ON THE PART OF EEMAX. EEMAX SHALL NOT BE LIABLE TO THE BUYER OR ANY THIRD PARTY FOR ANY LOSS, PERSONAL INJURY OR PROPERTY DAMAGE DIRECTLY OR INDIRECTLY ARISING FROM SUCH PRODUCT. UNDER NO CIRCUMSTANCES SHALL EEMAX BE LIABLE TO THE BUYER OR ANY THIRD PARTY FOR INCIDENTAL, CONSEQUENTIAL OR PUNITIVE DAMAGES OF ANY DESCRIPTION, WHETHER ANY SUCH CLAIM BE BASED UPON WARRANTY, CONTRACT, NEGLIGENCE, STRICT LIABILITY OR OTHER TORT, OR OTHERWISE.